

**I-9401N Addressable Sounder Strobe
Installation and Operation Manual
(Issue 1.02, December 2020)**





CONTENTS

I	General	1
II	Features	1
III	Technical Specifications.....	1
IV	Structure and Operation Principle.....	2
V	Mounting and Wiring	2
VI	Testing.....	3
VII	Applications.....	4
VIII	Product warnings and disclaimers	4

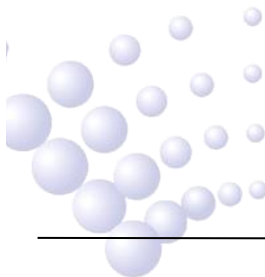

I General

Sounder Strobe is a kind of optical and visual alarm device used to warn people in field when fire occurs.

I-9401N addressable sounder strobe can be started directly by fire alarm control panel. It can be electronically programmed and modified by P-9910 Hand Held Programmer in field.

II Features

1. Red plexiglass panel, several strong red LED as light source, striking, long-life and low consumption.
2. Circuit part and base box are plugged together, reliable contact convenient for engineering;
3. The sounder strobe has two tones. Fire alarm tone is for fire given by fire alarm products and machine gun tone is for gas releasing warning.
4. Peripheral control terminals to startup the sounder strobe directly by passive normally open contact (e.g. manual call point), unaffected by power-cut of signal bus.
5. Signal bus and power bus non-polarized, easy for connection.
6. Function of checking power-cut, sending fault information to the control panel.
7. Electronic programming of address code that can be modified on site.

III Technical Specifications

1. Operating Voltage:
Signal Bus Voltage: 24V Range Allowed: 16V~28V;
Power Bus Voltage: DC24V Range Allowed: DC20V~DC28V
2. Operating Current:
Power Standby Current \leq 8mA;
Power Alarming Current \leq 37mA;
Loop Standby Current \leq 0.8mA;
Loop Starting Current \leq 3.0mA.
3. Flashing Frequency: 1.1Hz~1.8Hz (DC20V~DC28V)
4. Alarm Voice: 80dB~115dB(Due front 3m horizontal (A weighted))
Sound Pressure for Machine Gun Tone: 80dB~110dB(Due front 3m horizontal (A weighted))
5. Modulation Cycle: 3.2s~4.8s
Modulation Cycle for Machine Gun Tone: 0.5s~0.8s
6. Wiring: Four wires, non-polarized, two-loop to the control panel, non-polarized two-wire to the power.
7. Operating Environment:
Temperature:-10°C~+50°C
Relative Humidity \leq 95%, no condensation;
8. Where used: indoor
9. Dimension: 144mm×90mm×60.5mm (with base)

10. IP Rating: IP43
11. Material and Color of Enclosure: ABS/ ivory white, front inlaid with plexiglass/red
12. Weight: I-9401N: about 255g (with base)
13. Hole Distance: 65mm

IV Structure and Operation Principle

1. Structure of the sounder strobe is shown in Fig. 1.

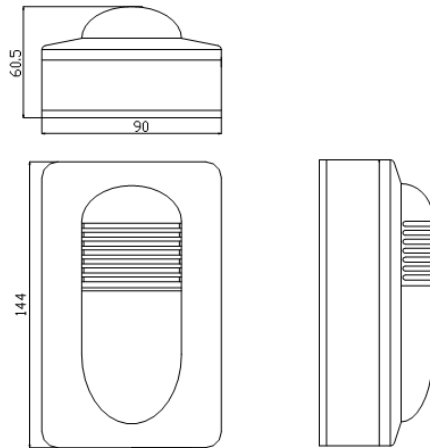

Fig. 1 Structure

2. Operation Principle:

Sounder strobes use sound effect chip amplified by dynatron and transformer to vocalize the speaker; 3 LEDs are controlled by timing circuit giving flashing light signal.

Intelligent sounder is built in with microprocessor, which execute communication with fire alarm control panel, checking power cut of the power bus and startup of audio and visual signals. Intelligent sounder strobe can start audio and visual signal after receiving startup command from fire alarm control panel or directly by outer controlling contact.

V Mounting and Wiring

Warning: Before installing the device, disconnect the power from the loop and verify that all bases are securely installed and that the wiring polarity is correct at each base.

1. The sounder strobe is wall-mounted. It should be 0.2m far from the ceiling in ordinary height space.
2. Check whether the enclosure sound or not, labels complete or not.
3. The base box and cover of the sounder strobe are plugged together, surfaced mounted on 85H50 embedded box as shown in Fig. 2.

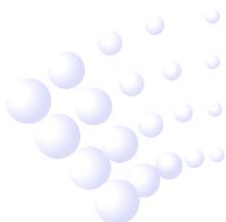

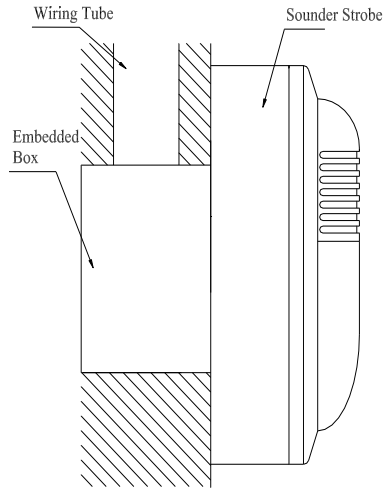

Fig. 2 Mounting

4. The base box of I-9401N is shown in Fig. 3, please note direction when installing.

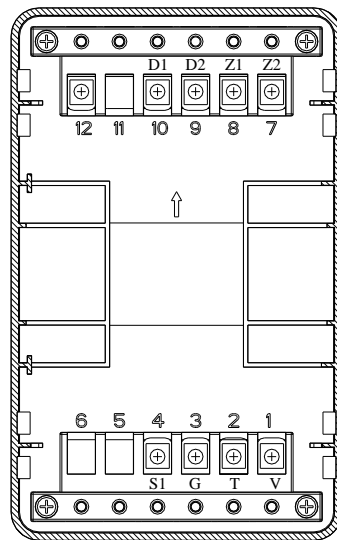

Fig. 3 I-9401N Base box

Terminals:

D1, D2: Connecting DC24V power, non-polarized;

Z1, Z2: Connecting signal loop of the control panel, non-polarized;

S1, G: Externally controlled passive input, started by shorting;

T, V: For selecting tone mode;

(Shorting those terminals, the sounder strobe gives machine gun tone for gas releasing warning as it is started; Not shorting terminals, the sounder strobe gives fire alarm tone for fire given by fire alarm products.)

5. Wiring: Twisted pair for signal loop Z1 and Z2, cross section $\geq 1.0\text{mm}^2$; 227IEC01 wire for power supply D1 and D2, cross section $\geq 1.5\text{mm}^2$.

VI Testing

Warning: Power up only after all devices are well connected.

1. Test should be made to the sounder strobe at least once a year after installation and

put into operation.

2. Before testing, notify the proper authorities that the system is undergoing maintenance and will temporarily be out of service. Disable the zone or system undergoing maintenance to avoid unwanted alarms.
3. Testing: Providing close signal to the outer control contact by manual call point, the sounder strobe is activated and gives audio and visual alarm; Cut the close signal of the outer control contact of the sounder strobe, give start command to the sounder strobe from the control panel, the sounder strobe is activated, gives audio and visual alarm, the sounder strobe is in normal operation.
4. After testing, sounder strobe can be reset by power cut. Notify the proper authorities the system is back on line.
5. If a sounder strobe fails in testing, check its connection and test again. If it still fails, return for repair.

VII Applications

The wiring of signal bus and power bus for intelligent sounder strobe and direct control through passive normally open contact of manual call point are shown in Fig.4:

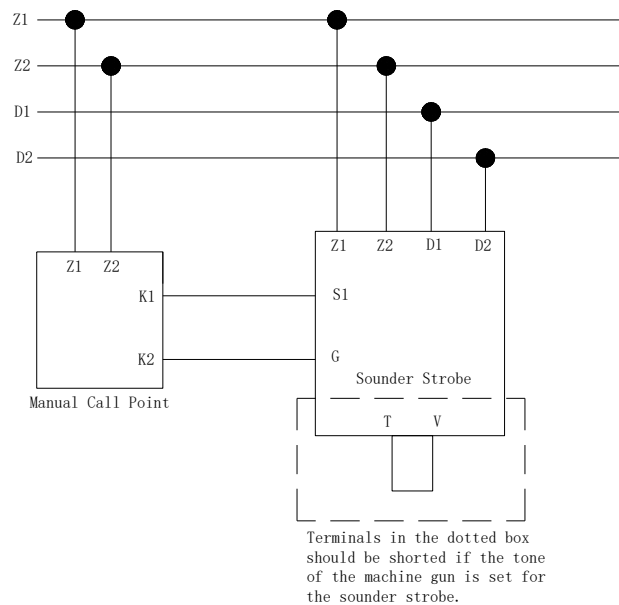

Fig.4 Wiring of signal bus and power bus for intelligent sounder strobe and direct control through passive normally open contact of manual call point

VIII Product warnings and disclaimers

THESE PRODUCTS ARE INTENDED FOR SALE TO AND INSTALLATION BY QUALIFIED PROFESSIONALS. CARRIER FIRE & SECURITY BV, CARRIER FIRE & SECURITY AMERICAS CORPORATION AND THEIR AFFILIATE COMPANIES (TOGETHER AND EACH INDIVIDUALLY "CARRIER") CANNOT PROVIDE ANY ASSURANCE THAT ANY PERSON OR ENTITY BUYING ITS PRODUCTS, INCLUDING ANY "AUTHORIZED DEALER" OR "AUTHORIZED RESELLER", IS PROPERLY

TRAINED OR EXPERIENCED TO CORRECTLY INSTALL FIRE AND SECURITY RELATED PRODUCTS.

For more information on warranty disclaimers and product safety information, please check <https://firesecurityproducts.com/policy/product-warning/> or scan the following code:

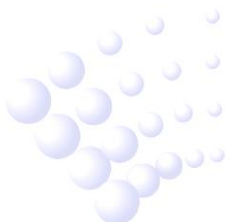



Gulf Security Technology Co., Ltd.

No. 80, Changjiang East Road, ETDZ, Qinhuangdao, Hebei, P. R. China 066004

Tel: +86 (0) 335 8502434

service.gst@carrier.com

www.gst.com.cn

30312588